

NO.	REV.	DATE	BY
1	CREATED	3/28/2022	MDN

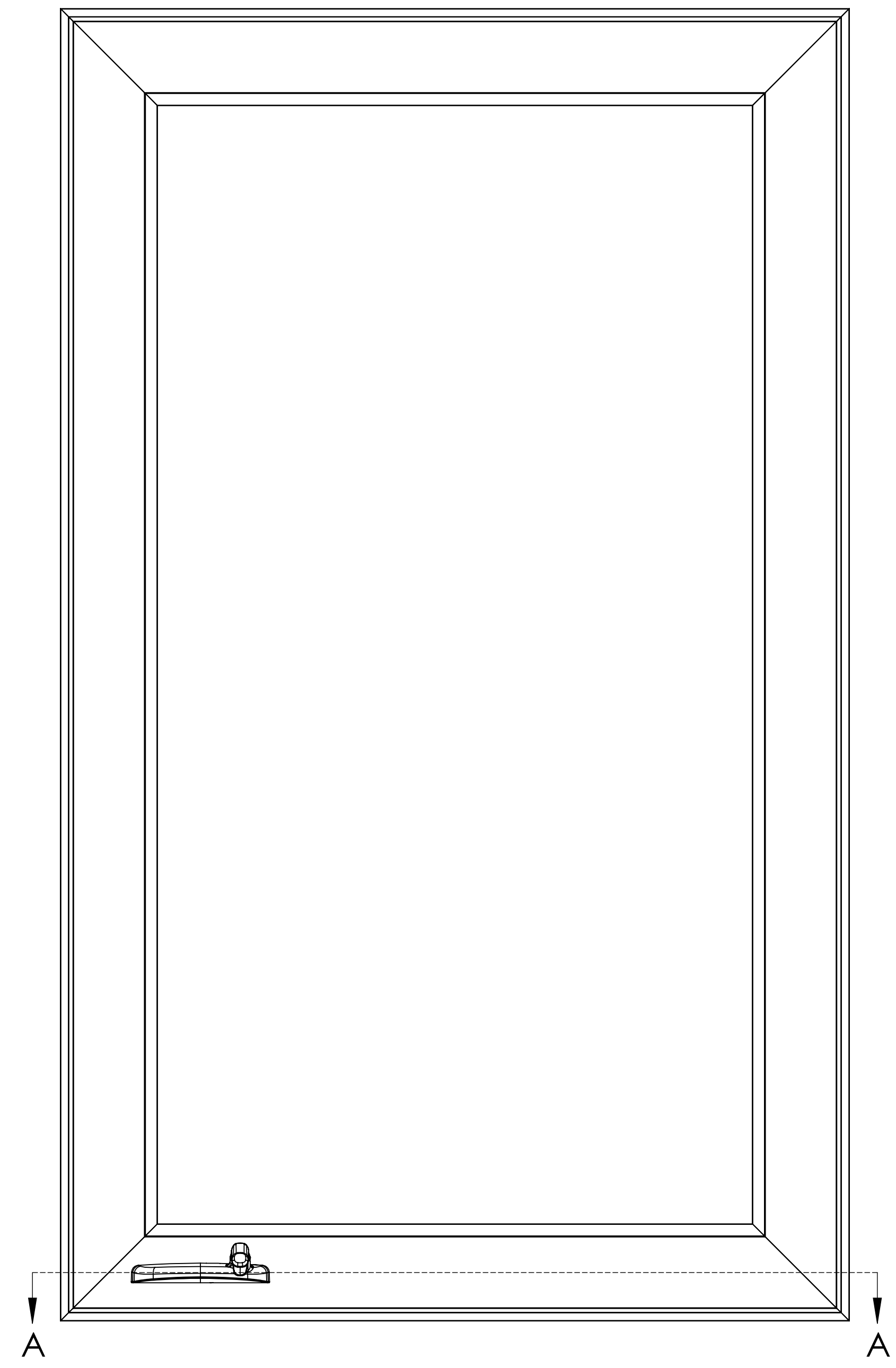
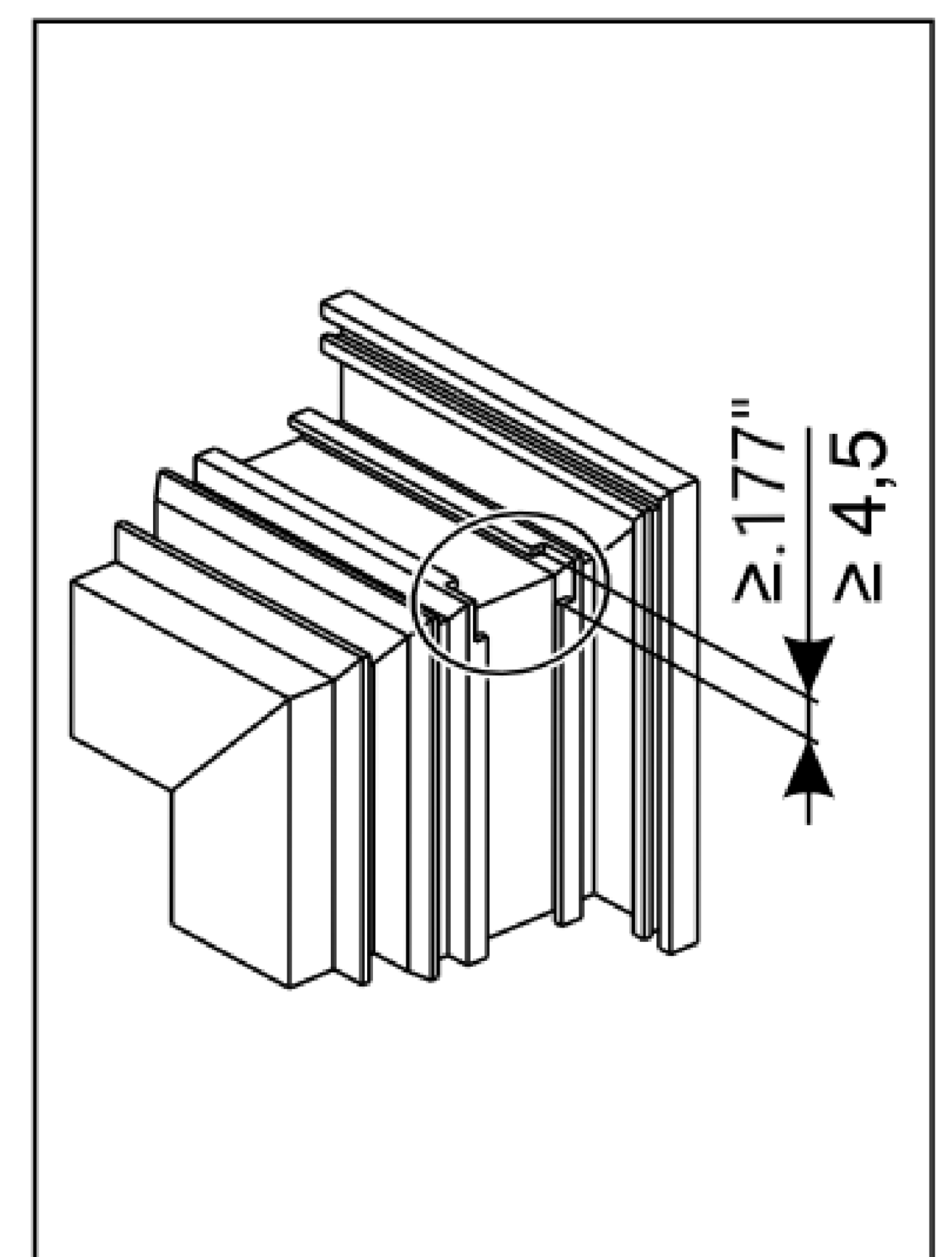
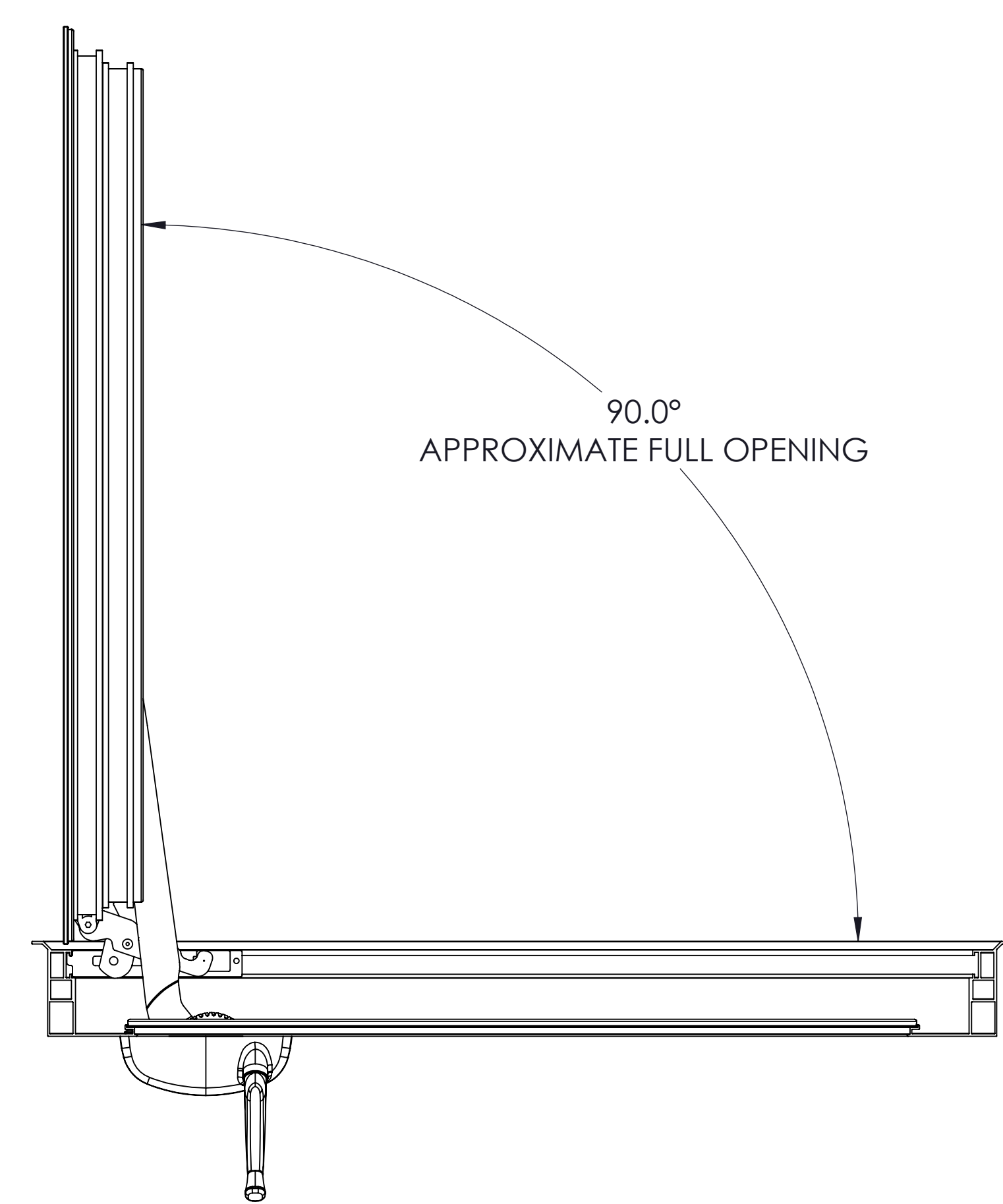
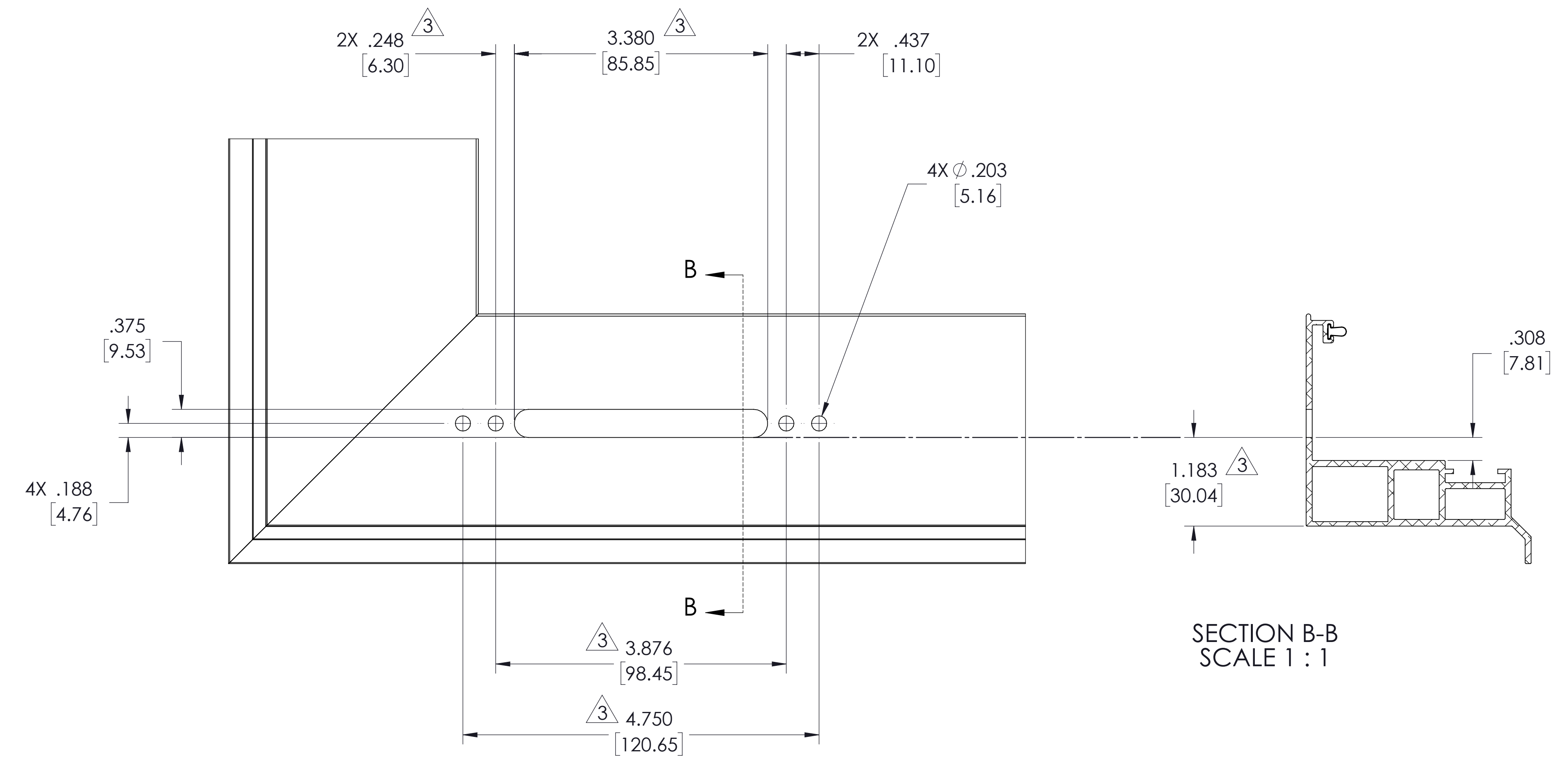
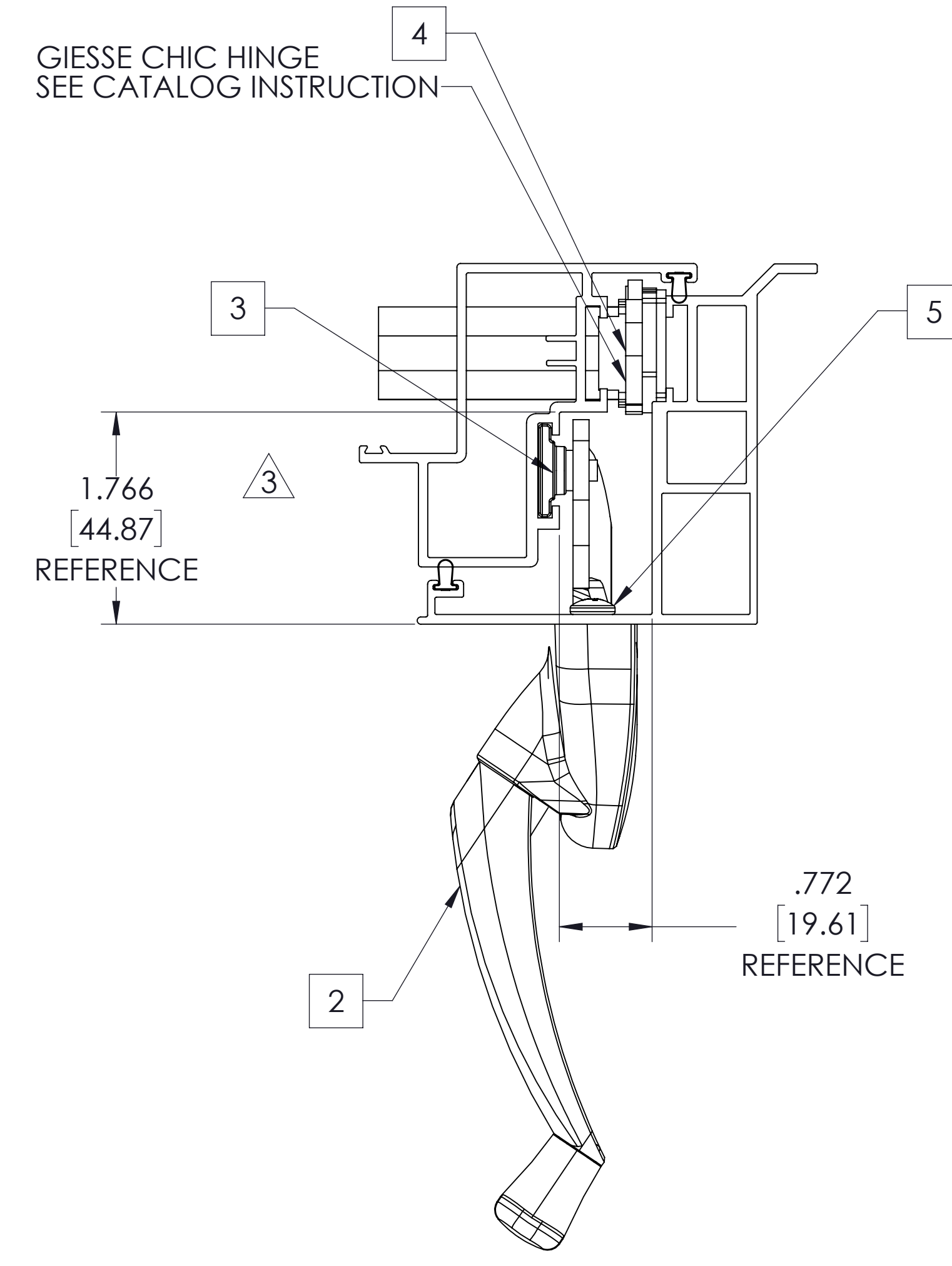
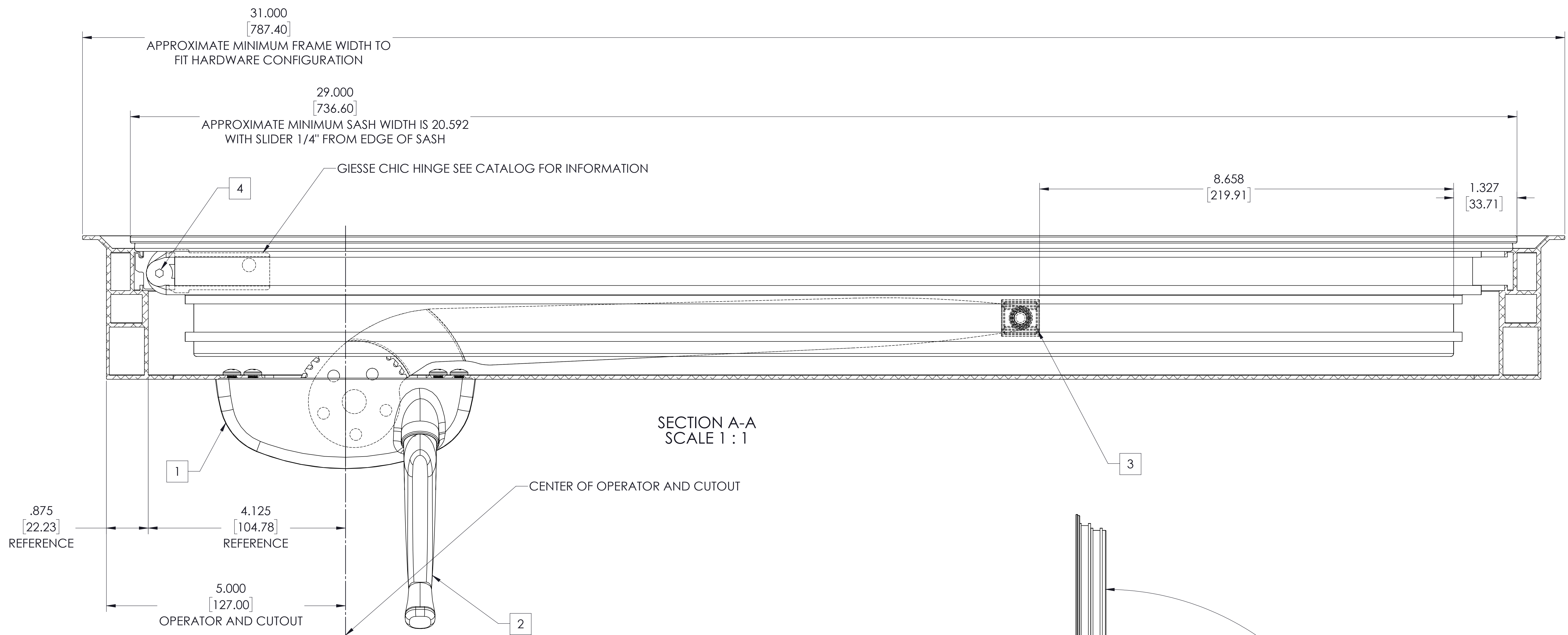

- NOTE:
- HARDWARE MAY ACHIEVE A MAXIMUM WINDOW SIZE OF 32" W X 72" H.
 - THE CHIC HINGES HAVE A SASH WEIGHT CAPACITY OF 220LBS. TO ACHIEVE ADA OF 5LB FORCE AT HANDLE THIS MUST BE DETERMINED BY WINDOW MANUFACTURER.
 - HOLD THESE DIMENSIONS AS CLOSE TO THEIR MINIMUM AS MANUFACTURING TOLERANCES ALLOW.
 - FOR INSTALLATION INFORMATION ON THE GIESSE EUROGROOVE HINGE SEE GIESSE CATALOG.

ITEM NO.	PART NUMBER	DESCRIPTION	QTY.
1	55.00.XX.221	SINGLE ARM OPERATOR 14 LH, CONTOUR	1
2	11454	HANDLE	1
3	24855	SLIDER, EUROGROOVE CASEMENT	1
4	043540001-2	CHIC SIDE HUNG HINGE R-L	1
5	N-A	SCREW, 10-32 X 3/8 T23 PH MS S518-8	4

TRUTH HARDWARE MAKES NO WARRANTY OR REPRESENTATION OF ANY KIND, EXPRESS OR IMPLIED, WITH RESPECT TO QUALITY, CONTENT, FORM, PERFORMANCE, FITNESS FOR PURPOSES, MERCHANTABILITY OR OTHERWISE OF THE APPLICATION DRAWINGS PROVIDED. THESE DRAWINGS ARE USED AT THE RECIPIENT'S OWN RISK AND TRUTH HARDWARE HAS AND SHALL HAVE NO RESPONSIBILITY FOR RECIPIENTS OR ANY THIRD PARTY'S USE OF THESE DRAWINGS OR ANY OF THE INFORMATION CONTAINED THEREIN. THE RECIPIENT AGREES TO INDEMNIFY, DEFEND, AND HOLD HARMLESS TRUTH HARDWARE AND ITS EMPLOYEES AND THEIR SUCCESSORS AND ASSIGNS FROM AND AGAINST ANY AND ALL CLAIMS, SUITS, LOSSES, DAMAGES OR COSTS INCURRED FROM USING THESE DRAWINGS OR ANY CONTENT THEREOF.

Amesbury Truth
 700 West Bridge Street
 Owatonna, MN 55060
 Telephone 507-451-5620

THIS DRAWING IS THE PROPERTY OF TRUTH HARDWARE. THE INFORMATION THEREON IS TO BE TREATED AS CONFIDENTIAL. IF IT IS NOT TO BE USED, COPIED, OR DISCLOSED TO OTHER PARTIES, PLEASE CONTACT TRUTH HARDWARE.

DRAWN BY: M. NEFF DATE: 3/28/2022
 CHECKED BY: MDN SCALE: 1:4
 PARTNAME: GENERIC CONTOUR EURO GROOVE SINGLE ARM OPERATOR

THIS DRAWING CONFORMS TO ANSI Y14.5M - 1992
 PROJECT: GENERIC ALUM EURO 21257V
 DRAWING NO.: 21257V
 REVISION: A
 TITLE: E

DO NOT SCALE DRAWINGS